

wallas®



86D Oven

**Three Year
Warranty**



87D stove/oven

SAFEFLAME 86D diesel oven and 87D stove/oven

- Safe, no-open flame operation.
- All combustion exhaust gases and water vapor is vented outside, keeping cabin dry.
- Clean, soot-free, reliable design minimizes maintenance.
- 87D has a great looking ceramic cook top for easy cleaning.
- Diesel fuel can be drawn directly from the main fuel tank or from a day tank.
- Super quiet, variable output eliminates off/on system cycling.
- Superb corrosion free stainless steel and aluminum construction.
- Convection oven for fast, accurate cooking times.
- Either model may be gymbol mounted with optional kit.

Imported and Distributed by:



Factory Authorized Sales & Service Center

2144 Westlake Ave N Suite D
Seattle, WA 98109 USA
PH: 206-285-3675 Fax: 206-285-9532
service@scanmarineusa.com
www.scanmarineusa.com

Wallas SAFEFLAME 87D diesel oven/stove and 86D diesel oven

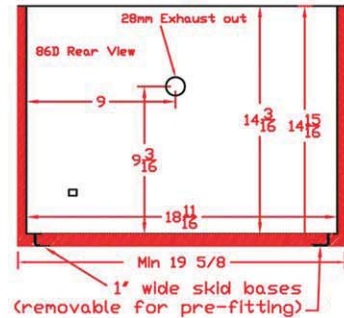
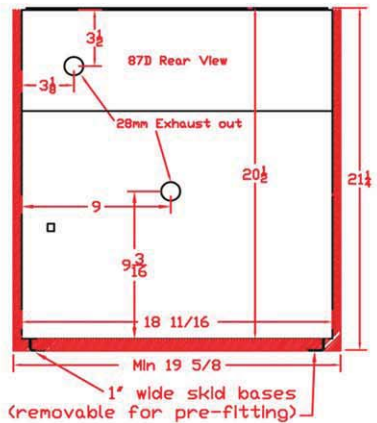
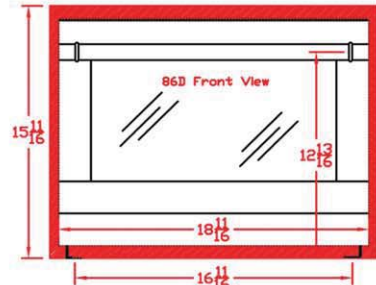
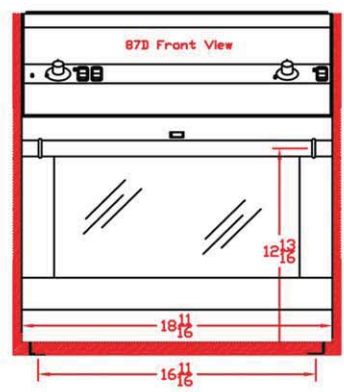
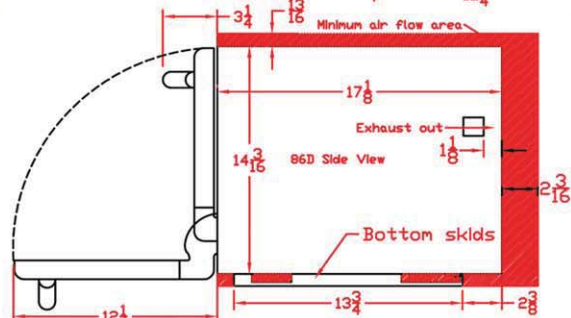
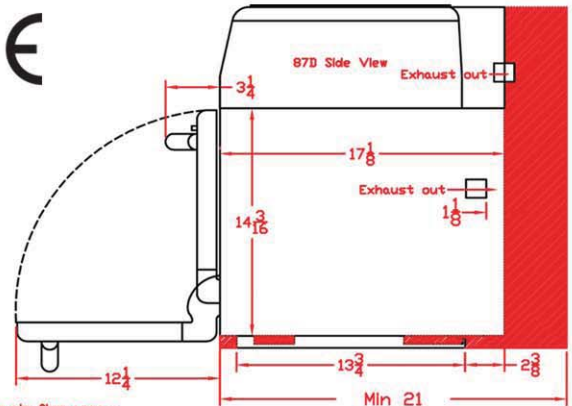
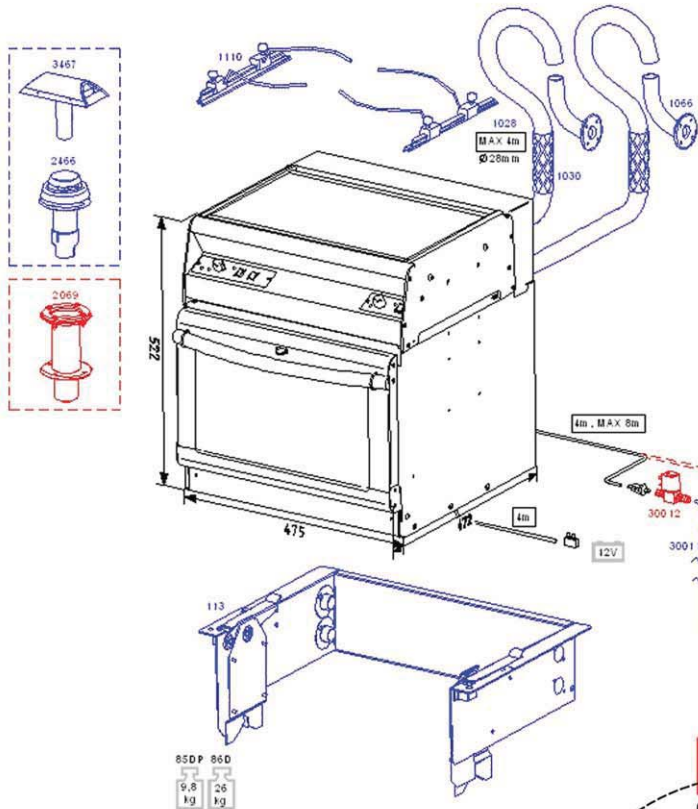

SPECIFICATIONS:

Stove Section (87D only):

Surface temperature: 210 to 1025 F
 Fuel Consumption: 3 to 5 oz/hour
 Voltage: 12V DC
 Power Consumption: .15 Amp

Oven Section:

Oven temperature: 210 to 485 F
 Fuel Consumption: 3.4 to 7.4 oz/hour
 Voltage: 12V DC
 Power Consumption: .15 Amp
 Starting amperage: 8 Amp for 7 min.

Weight - 86D: 24.5 kg (54 lb)
 Weight - 87D: 33.1 kg (73 lb)

ACCESSORIES:

- 3468 Duplex Through Deck
- 3467 Thru Deck
- 2467 Duplex Thru Hull
- 1066 Thru Hull
- 1028 Exhaust Hose
- 1029 Exhaust Hose Insulation
- 1110 Potholders
- 113 Gimbal set
- 30011 Fuel Suction Fitting for Main Tank

Measurements in inches



2144 Westlake Ave N., Suite D
 Seattle, WA 98107
 Toll Free: 1-888-606-6665
 Ph. 206-285-3675 Fax: 206-285-9532